

Steering guide-based lateral control for roll-to-roll printed electronics[†]

Hyeunhun Shin, Thanhnam Ho and Sangyoon Lee*

Department of Mechanical Design and Production Engineering, Konkuk Univ., Seoul, Korea

(Manuscript Received May 4, 2009; Revised October 1, 2009; Accepted October 16, 2009)

Abstract

This paper presents the lateral displacement control of a moving web using a steering guide system which can be an important part in roll-to-roll (R2R) printed electronics. In general, R2R systems in printed electronics need a long drying section for the reduction of time and cost by reducing the delay of drying time. However, the lateral web displacement can be a worse problem because the web should be affected by the air blow from the dryer. Therefore, the lateral position control of long span will play a significant role in the R2R production process for better product quality. In our work, PID control method is designed to control the lateral displacement of a moving web by using a steering guide system, and simulations and experiments were performed to test the method.

Keywords: Roll-to-roll (R2R) process; Lateral displacement control; Steering guide system; PID control; Printed electronics

1. Introduction

The roll-to-roll (R2R) process is a continuous production process which has been popularly used in the traditional printing and packaging industry. Recently, it has been estimated to have the potential to be a cost-effective technology for mass production of electronic devices [1–4]. Examples of products can be RFID, electronic paper, solar cells, flexible displays, etc.

For the success of the R2R system in printed electronics, precise control of the system is essential. As one of the key elements in the system control, the lateral control of a moving web should be even more important in printed electronics than for the traditional printing process.

In R2R systems, guide systems are usually used to correct the lateral displacement of a moving web. A displacement guide system is often used in many R2R systems [5]. However, in the case of a long span, a steering guide system can be a suitable way to control the lateral displacement of the web.

This work concerns the R2R printing system for the fabrication of an RFID antenna that requires a long dryer section. The long dryer causes external changes such as air blow of dryer. In addition, the web is thin and flexible like film and the width of web is small. Therefore, a steering guide system with a long span can be a suitable selection.

This paper reports the model of steering guide system and

PID control simulation. In addition, it presents the experimental work for the lateral of the web with a long span dryer using the steering guide system.

2. Model and simulation

In this section, we introduce Shelton's first order mathematical model that describes the web movement [6, 7] and simulation work with Matlab Simulink that includes a long span drying process.

2.1 Mathematical model

To do simulation and control work, mathematical models are necessary. Shelton's first order model presents the dynamics of a moving web that includes the relation of the lateral velocity to the longitudinal velocity and the input error. This model is built under the principle that the web in the entering span aligns itself perpendicularly to the roller. It is assumed in the model that the mass and the lateral stiffness of the web are negligible.

The idealized web behavior with an input error is shown in Fig. 1. There are two expressions that express the lateral displacement and the lateral velocity in Eq. (1) and (2) where l is the distance between two rollers, V is the line speed, θ_r is the angle between the roller and Y axis, and θ_L is the web angle measured with respect to the X axis.

$$\Delta y = l(\theta_L - \theta_r) \quad (1)$$

$$V_L = V(\theta_L - \theta_r) \quad (2)$$

[†] This paper was presented at the ICMDT 2009, Jeju, Korea, June 2009. This paper was recommended for publication in revised form by Guest Editors Sung-Lim Ko, Keiichi Watanuki.

*Corresponding author. Tel.: +82 2 450 3731, Fax.: +82 2 447 5886

E-mail address: slee@konkuk.ac.kr

© KSME & Springer 2010

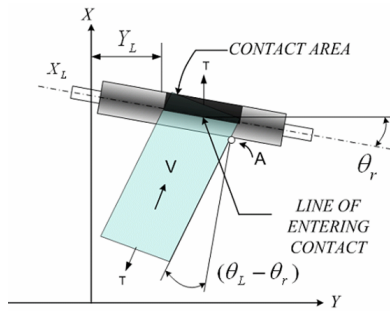

Fig. 1. Steering action of an idealized web.

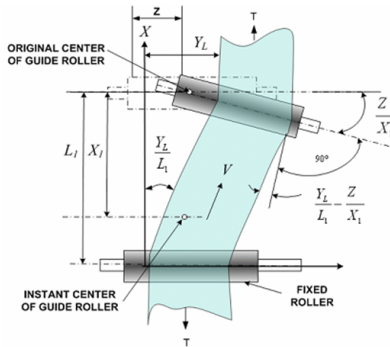

Fig. 2. Symbols and arrangement for derivation of steering guide response.

If the roller moves laterally and Z is the position of the roller relative to the ground, the first order equation of lateral velocity is obtained as in Eq. (3).

$$\frac{dy_L}{dt} = V(\theta_L - \theta_r) + \frac{dz}{dt} \tag{3}$$

Fig. 2 shows a steering guide with the instant center of a distance L_1 and the entering span has the length of L . The lateral displacement of the roller is input, Z and the displacement of the web is output, Y_L .

The angle between the guide roller and the web is $(Y_L/L) - (Z/L_1)$. From Eq. (3), the following equation is obtained.

$$\frac{dy_L}{dt} = -V\left(\frac{Y_L}{L} - \frac{z}{L_1}\right) + \frac{dz}{dt} \tag{4}$$

If we let $T_1 = L/V$, Eq. (4) may be written as (5) by taking the Laplace transform.

$$\frac{Y_L(s)}{Z(s)} = \frac{T_1 s + (L/L_1)}{T_1 s + 1} \tag{5}$$

2.2 Simulation of PID control

This section describes the design of PID controller and simulation results. Fig. 3 illustrates the R2R simulator model, which is used for lateral position control simulation. The R2R

Table 1. Simulation conditions for steering guide system.

Parameter	Symbol	Value
Distance between first sensor and second sensor	L_p	7 m
Distance from roller to centre point	L_1	3.5 m
Length span from guide to roller	L_2	0.4 m
Length span from guide to sensor	X	0.2 m
Web line speed	V	10~30mpm
Web material		PET

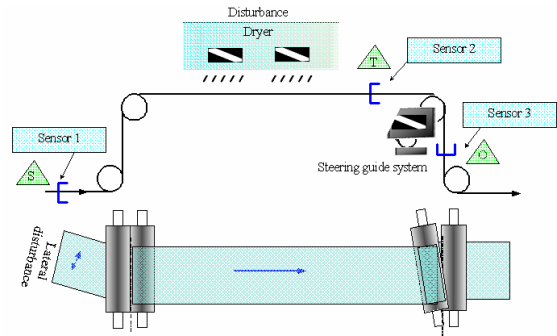

Fig. 3. Simulation model for steering guide system.

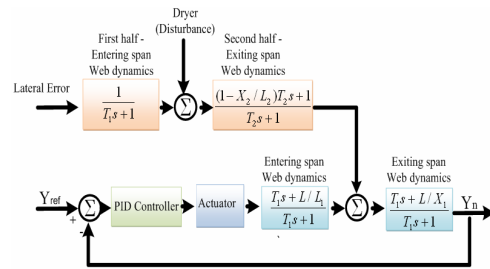

Fig. 4. PID control block diagram for steering guide system.

simulator system includes a dryer that serves as an additional error source and a model of steering guide system that corrects the lateral error.

Fig. 4 shows the block diagram of the whole simulation system which includes a DC motor model, a steering guide system model, a PID control system and the combination of web dynamics of the various span models [8].

Fig. 4 also displays the block diagram of lateral disturbance generation and transfer process. Three sensors are set at points S, T, and O to detect edge position of web (see Fig. 3). Sensor 1 at position S measures the input error and it gives the value of lateral error at this point. Sensor 2 observes the lateral error before the steering guidance at T. The output value of sensor 3 at position O is the lateral error at the controlled position and this sensor signal is fed back to the controller.

The simulation model for lateral position control is built in Matlab Simulink. Parameters of the motor model are from DC brush motor ID23007 (MCG Motion control group). The detailed information of simulation conditions is presented in Table 1. Fig. 5 shows the simulation results of the steering guide system at different line speeds.

In the simulation, we assumed the initial state of 10 mm lat-

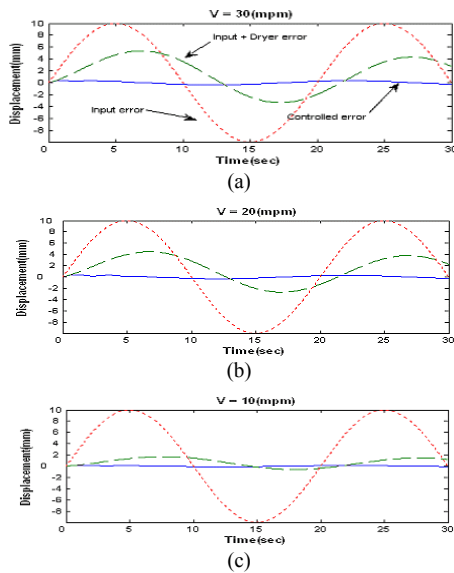

Fig. 5. Sine response of PID control at different line speeds (Input error = 10 mm, dryer error = 3 mm, 0.05 Hz).

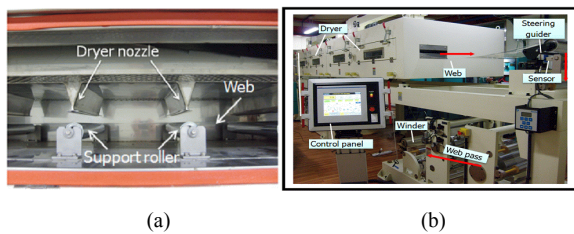

Fig. 6. (a) Inside of dryer, (b) R2R system for RFID antenna printing.

eral error in the sine form and 3 mm lateral displacement from the dryer. The line speed was set 30, 20, 10 mpm. The line conditions were set to simulate R2R production of RFID antenna. The amount of input error was set quite large, considering the line speed is low.

Fig. 5 shows simulation results that the solid line is controlled lateral displacement measured at O and the long dotted curve is lateral displacement measured at T in Fig. 3. The initial input error (short dotted line) was measured at S. We used 100, 21, 15 for P, I, D gains, respectively, and the web tension is not considered in the simulation. The range of the controlled error was measured approximately within 200 micron, although the input error of 10 mm is quite large.

The results show that if the driving speed passing through the guide system is reduced, the controlled displacement error also decreases. It was confirmed that the displacement error due to the influence of air blow of dryer significantly increases the displacement transferred to steering guide system. Therefore, in order to control the lateral displacement precisely, the lateral displacement caused by dryer should be minimized.

3. Experiments and results

This section reports the experiments and results using the R2R printing machine for the fabrication of RFID antenna.

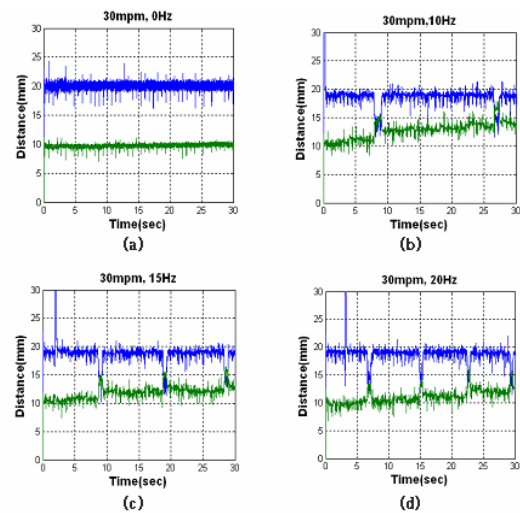

Fig. 7. Test results of lateral displacement of web passing through the dryer (a) without running the dryer, (b), (c), (d) with running the dryer at different air blowing frequencies.

While maintaining a certain tension and the driving speed of the R2R printing machine, the displacement change caused by dryer air blow is measured. The lateral displacement error was controlled by the PID controller and software which we designed and built.

3.1 Experimental equipment

For the lateral displacement control experiments, we used an RFID antenna printing machine. It contains a gravure printer unit, a dryer, and a commercial steering guide system [9].

Fig. 6(a) shows the main parts of the inside of the dryer. The dryer consists of the support roller, the air nozzle and the electric heater. Fig. 6(b) shows the RFID antenna printing machine designed for multi-layer coating and printing. The web material is PET, which has about 400 mm in diameter that can be used as a winding or unwinding roll.

Based on the assumption that the air injected through the nozzle causes the web to vibrate passing through the dryer, the lateral displacement was measured in the experiment. Measured data including the noise during the transport of the web was stored in a pc through a DAQ board and was displayed in the graph using Matlab.

3.2 Experimental results

Experimental data was measured under the condition of no change of tension and line speed. That is, the web is transported at a normal state.

The conditions of the experiment were set in the constant 3 kgf tension and printing speed of 30 mpm, which were the conditions for RFID antenna production using R2R system. In addition, the air blow from the dryer generates lateral displacement on the web.

Fig. 7 shows the results of the experiments where we measured the lateral displacement through the dryer. For compari-

son of the responses, Fig. 7 (a) shows the response when the dryer did not run and Fig. (b), (c), (d) show the responses when the driving speed was 30 mpm and the air blowing frequency from the dryer was 10, 15, 20 Hz during 30 seconds, respectively.

The upper curve of Fig. 7 (a)-(d) is the controlled signal, which is measured by a commercial infrared sensor [10] installed in the R2R system. The sensor has the same position as the position O in Fig. 5. The lower curve of Fig. 7 shows the measured signal before passing the steering guide system, which corresponds to the position T.

In spite of increasing the air blow frequency, the amount of controlled displacement does not change much, because the displacement caused by the dryer is very small compared with the observation time of about 30 seconds. If the effect of measurement noise is neglected, the control accuracy can be less than 500 micron. It is observed that as the air blow frequency increases, the lateral displacement decreases. It is considered because of the friction in the contact area of the support roller and web by the pressure of dryer nozzle.

4. Conclusions

We have reported the mathematical model of the steering guide, design of PID control method, simulations and experiments for the lateral control of a moving web. In particular, the effect of the air blow of drying section is included in the work, since our work aims to be applied for the fabrication of RFID antenna by means of R2R printing.

It is found from simulations and experiments that if the line speed of web is reduced, the amount of lateral displacement error that can be controlled by the steering guide system also decreases. If the input error decreases, the lateral displacement error also becomes smaller. It is observed that the lateral displacement occurs on the transported web by the air blow from the dryer and we also found that the increase of blowing frequency can reduce the lateral displacement.

Therefore, for the precise control of lateral displacement, the error caused by the air blow of the dryer should be minimized and the driving speed must be under control to reduce the lateral displacement.

Since printed electronics covers a variety of products, simulations and experiments with more diverse conditions are necessary, which is included in our future work. It is expected that the proposed method in this research can be helpful to improve the process technology for R2R printed electronics.

Acknowledgment

This work was supported by Seoul R&BD Program (10848) and the Korea Foundation for International Cooperation of Science & Technology (KICOS) through a grant provided by the Korean Ministry of Education, Science & Technology (MEST) in K20701040600-09A0404-05410.

References

- [1] H. Kopola, Technological challenge and state-of-the art in R2R printed electronics, *Proc. of 1st International Conference on R2R Printed Electronics*, Seoul, Korea (2008) 31-48.
- [2] H. M. Zang and R. C. Liang, Microcup electronic paper by roll-to-roll manufacturing processes, *The Spectrum*, 16 (2) (2003) 16-21.
- [3] S. H. Ahn and L. J. Guo, High-speed roll-to-roll nanoimprint lithography on flexible plastic substrate, *Adv. Matr.*, 20 (2008) 2044-2049.
- [4] T. K. Kololuoma, M. Tuomikoski, T. Makela, et al., Towards roll-to-roll fabrication of electronics, optics and optoelectronics for smart and intelligent packaging, *Proc. SPIE*, Bellingham, Washington, USA (2004) 77-85.
- [5] T. Ho, H. Shin and S. Lee, *Fuzzy Control of the Lateral Position of a Moving Web in Roll-to-Roll Processes*, *Proc. of IEEE ROBIO*, Bangkok, Thailand (2008) 1637-1642.
- [6] J. J. Shelton, *Lateral Dynamics of a Moving Web*, Ph.D dissertation, Oklahoma State University (1968).
- [7] J. J. Shelton and K. N. Reid, Lateral dynamics of an idealized moving web, *Trans. ASME J. Dyn. Syst. Meas. Control*, ser G, 3 (1971) 187-192.
- [8] R. C. Dorf and R. H. Bishop, *Modern Control Systems*, Prentice Hall, New Jersey, USA (2000).
- [9] Steering guide system, http://www.fife.com/fife_products_fife_kantiroller.asp.
- [10] Infrared edge sensor (SE-23, FIFE).
- [11] http://www.fife.com/fife_products_fife_se23.asp.



Hyeunhun Shin received his B.S. and M.S. in Mechanical Design and Production Engineering from Konkuk University, KOREA, in 2007 and 2009, respectively. Mr. Shin's research interests include roll-to-roll (R2R) process, lateral displacement control, guide system.



Thanhtam Ho received the B.S. in Mechatronics from Hochiminh City University of Technology, Vietnam in 2005 and M.S. in 2008 from Konkuk University, Korea, where he is currently pursuing the Ph.D degree. His research interests include biomimetic robots, lateral control for R2R system and computational simulation.



Sangyoon Lee received the Ph.D in Mechanical Engineering from Johns Hopkins University in 2003. Since then, he has been a professor at Konkuk University. His research interests include robotics, automation, and robotics applications to bioengineering.